

GUH/DD 80 Series

High Efficiency Upflow/Horizontal and Downflow Gas Furnaces

Induced Draft - 80+ AFUE
Input 45,000 - 126,000 Btuh

The high efficiency gas furnace may be installed free standing in a utility room, basement, or enclosed in an alcove or closet. The rounded corner jacket provides a pleasing "appliance appearance." Design certified by CSA for application in Canada and the United States.



FEATURES and BENEFITS

- **100% fired and tested:** All units and each component are tested on the manufacturing line.
- **Best packaging in the industry:** Unique corner post design assures product will arrive to the homeowner dent free.
- **Low Boy Height:** Easy to apply in low ceiling applications, works well with taller high SEER coils, easier to handle and install.
- **Tubular primary heat exchanger:** Heavy gauge aluminized steel heat exchanger assures a long life.
- **30 second blower delay at start-up:** Assures a warm duct temperature at furnace start-up. Adjustable blower off settings (60, 90, 120 and 180 seconds).
- **30 second post purge:** Increases life of heat exchanger.
- **Hot surface igniter:** Innovative application of a silicon nitride igniter. Utilizes proven Smartlite® technology.
- **Color coded wire harness:** Designed to fit the components, all with quick-connect fittings for ease of service and replacement.
- **High static blowers:** All models equipped with high static blowers.
- **90 second cooling cycle blower-off delay (TDR):** increases performance in cooling.
- **Flexible category I venting system:** May be vented with dedicated venting system or common vented with other category one appliances.
- **High efficiency blower kits:** Maximize efficiencies. On select units, a SEER improvement of up to 1 point is realized.
- **Multi-speed direct drive blower:** Designed to give a wide range of cooling capacities. Switches on PCB, provide ultra easy motor speed selection.
- **LP convertible:** Simple burner orifice and regulator spring change for ease of convertibility.
- **Diagnostic lights for easy troubleshooting without counting flashes:** Dedicated light for flame signal strength and 2 lights in combination to indicate all other fault codes with easy to recognize states without counting flashes.
- **Integrated control board:** Incorporates connections for electronic air cleaner and humidifier.
- **Two piece door design:** Enhances furnace appearance and uses captured screws to prevent loosening door screws.
- **Blower Compartment:** Insulated for ultra quiet operation.
- **Furnace Air Leakage:** These furnaces comply with Energy Star cabinet air leakage requirement of less than or equal to 2%. Keep the conditioned air flowing to where it's needed.

GAS FURNACE COMPONENTS

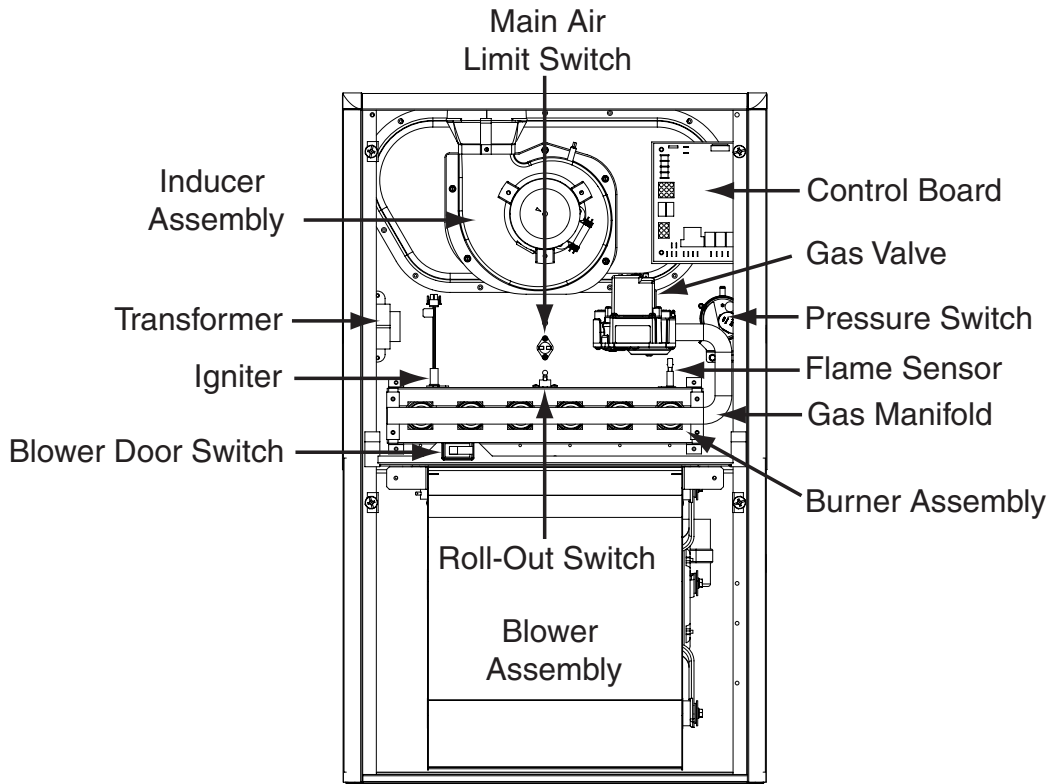

Upflow/Horizontal Gas Furnace

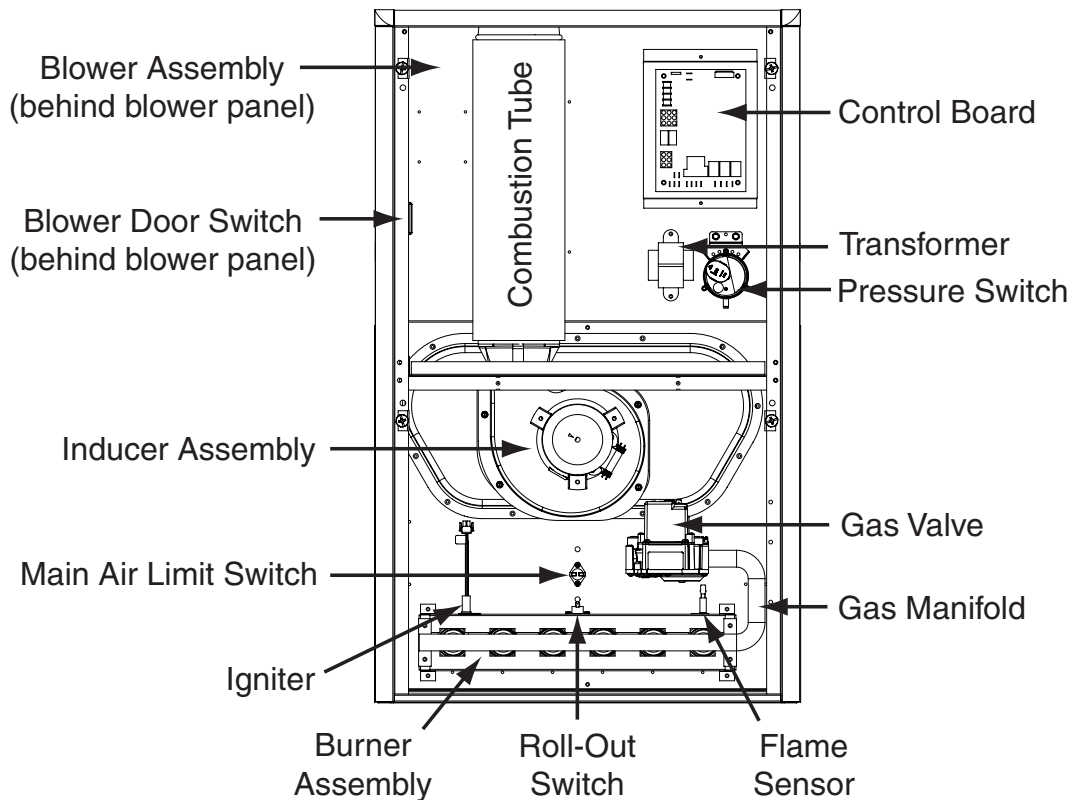

DIMENSIONS

GUH Model #'s	Dimension "A"	Dimension "B"	Dimension "C"	Dimension "D"
045A3XE	14 1/4	10 3/4	12 5/8	12 7/8
054A3XE				
072B4XE				
090B4XE	17 1/2	11 3/4	15 7/8	16 1/8
072C5XE	21	14	19 3/8	19 7/8
090C5XE				
108C5XE				
126D5XE	24 1/2	15 1/4	22 7/8	23 1/8

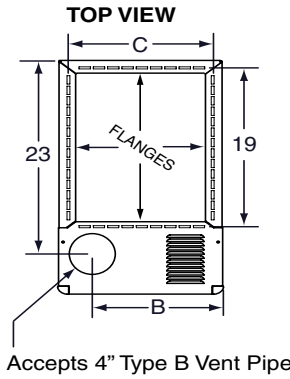

Accepts 4" Type B Vent Pipe

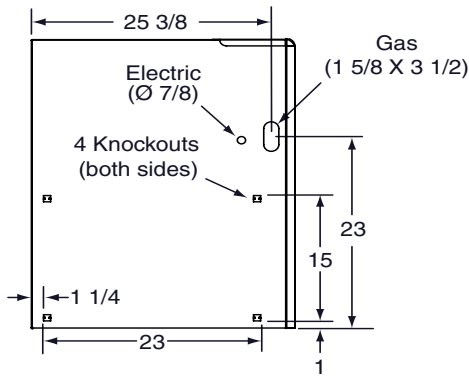

LEFT SIDE

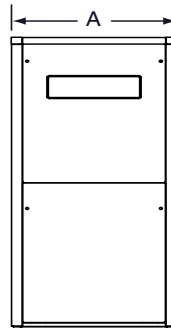

FRONT VIEW

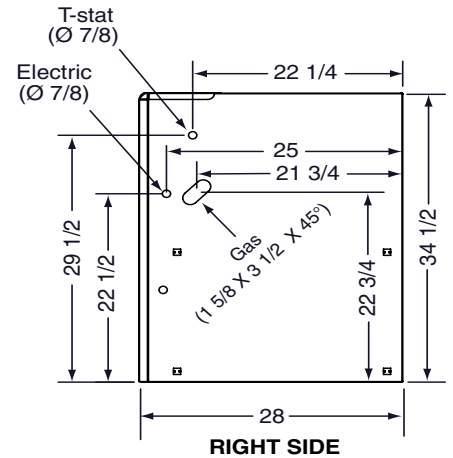

RIGHT SIDE

GUH 80+ High Efficiency Upflow/Horizontal Series

GDD Model #'s	Dimension "A"	Dimension "B"	Dimension "C"	Dimension "D"
054A3XE	14 1/4	10 3/4	12 5/8	12 7/8
072B4XE				
090B4XE				
108C5XE	21	14	19 3/8	19 3/8
126D5XE	24 1/2	15 1/4	22 7/8	23 1/8

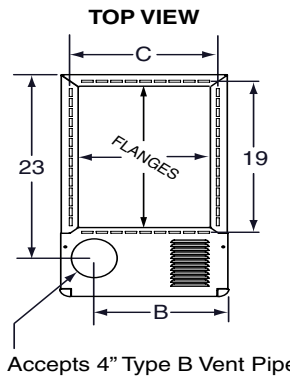

Accepts 4" Type B Vent Pipe

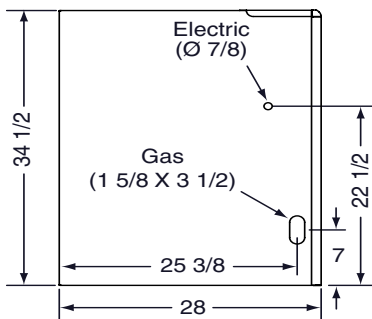

LEFT SIDE

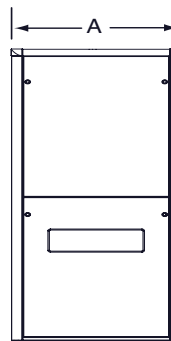

FRONT VIEW

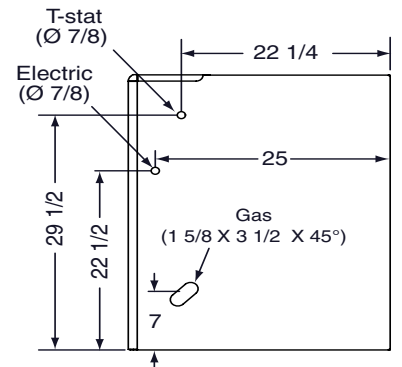

RIGHT SIDE

GDD 80+ High Efficiency Downflow Series

BLOWER PERFORMANCE - GUH

AIRFLOW DATA

GUH80A - UPFLOW / HORIZONTAL FURNACES - 80+ AFUE																	
Model Number & Heating Input (Btuh)	Motor Speed	External Static Pressure (Inches Water Column)															
		0.1		0.2		0.3		0.4		0.5		0.6		0.7		0.8	
		CFM	Rise	CFM	Rise	CFM	Rise	CFM	Rise	CFM	Rise	CFM	Rise	CFM	Rise	CFM	Rise
045A3XE Bottom Return (45,000)	High*	1,260	26	1,205	28	1,145	29	1,080	31	1,025	33	960	35	890	37	825	40
	Med-High	955	35	950	35	940	35	935	36	925	36	860	39	800	42	725	46
	Med-Low**	825	40	800	42	760	44	730	46	690	48	650	51	600	56	530	63
	Low	655	51	630	53	610	55	580	57	550	61	520	64	480	69	435	77
045A3XE Side Return (45,000)	High*	1,350	25	1,290	26	1,225	27	1,155	29	1,100	30	1,025	33	950	35	885	38
	Med-High	1,025	33	1,015	33	1,005	33	1,000	33	990	34	920	36	855	39	775	43
	Med-Low**	885	38	855	39	815	41	780	43	740	45	695	48	640	52	565	59
	Low	700	48	675	49	655	51	620	54	590	56	555	60	515	65	465	72
054A3XE Bottom Return (54,000)	High*	1,260	32	1,205	33	1,145	35	1,080	37	1,025	39	960	42	890	45	825	48
	Med-High**	955	42	950	42	940	43	935	43	925	43	860	47	800	50	725	55
	Med-Low	825	48	800	50	760	53	730	55	690	58	650	62	600	67	530	75
	Low	655	61	630	63	610	66	580	69	550	73	520	77	480	83	435	92
054A3XE Side Return (54,000)	High*	1,350	30	1,290	31	1,225	33	1,155	35	1,100	36	1,025	39	950	42	885	45
	Med-High**	1,025	39	1,015	39	1,005	40	1,000	40	990	40	920	43	855	47	775	52
	Med-Low	885	45	855	47	815	49	780	51	740	54	695	58	640	63	565	71
	Low	700	57	675	59	655	61	620	65	590	68	555	72	515	78	465	86
072C5XE Bottom Return (72,000)	High*	1,685	32	1,640	33	1,605	33	1,565	34	1,515	35	1,475	36	1,415	38	1,345	40
	Med-High	1,330	40	1,295	41	1,275	42	1,245	43	1,215	44	1,185	45	1,135	47	1,070	50
	Med-Low**	1,175	45	1,155	46	1,125	47	1,100	48	1,075	50	1,045	51	1,010	53	955	56
	Low	930	57	895	60	885	60	850	63	825	65	800	67	770	69	740	72
072C5XE Side Return (72,000)	High*	1,770	30	1,720	31	1,685	32	1,645	32	1,590	34	1,550	34	1,485	36	1,415	38
	Med-High	1,400	38	1,360	39	1,340	40	1,310	41	1,275	42	1,245	43	1,190	45	1,125	47
	Med-Low**	1,235	43	1,215	44	1,180	45	1,155	46	1,130	47	1,100	48	1,060	50	1,005	53
	Low	975	55	940	57	930	57	890	60	865	62	840	63	810	66	775	69
090B4XE Bottom Return (90,000)	High*	1,610	41	1,575	42	1,530	44	1,485	45	1,440	46	1,385	48	1,340	50	1,275	52
	Med-High**	1,295	51	1,260	53	1,235	54	1,220	55	1,175	57	1,135	59	1,095	61	1,015	66
	Med-Low	1,155	58	1,130	59	1,100	61	1,070	62	1,035	64	1,015	66	965	69	920	72
	Low	880	76	860	78	830	80	800	83	765	87	740	90	675	99	660	101
090B4XE Side Return (90,000)	High*	1,690	39	1,655	40	1,610	41	1,560	43	1,510	44	1,455	46	1,405	47	1,340	50
	Med-High**	1,360	49	1,325	50	1,300	51	1,280	52	1,235	54	1,190	56	1,150	58	1,065	63
	Med-Low	1,215	55	1,190	56	1,155	58	1,125	59	1,090	61	1,065	63	1,015	66	965	69
	Low	925	72	900	74	870	77	840	79	800	83	775	86	710	94	695	96
072C5XE Bottom Return (72,000)	High*	1,950	27	1,865	29	1,790	30	1,715	31	1,630	33	1,550	34	1,475	36	1,390	38
	Med-High	1,860	29	1,780	30	1,710	31	1,635	33	1,575	34	1,500	36	1,415	38	1,325	40
	Med-Low**	1,300	41	1,240	43	1,200	44	1,160	46	1,120	48	1,065	50	995	54	910	59
	Low	1,165	46	1,115	48	1,060	50	1,025	52	985	54	940	57	890	60	825	65
072C5XE Side Return (72,000)	High*	2,030	26	1,940	27	1,860	29	1,785	30	1,695	31	1,615	33	1,535	35	1,445	37
	Med-High	1,935	28	1,850	29	1,780	30	1,700	31	1,640	34	1,560	34	1,470	36	1,380	39
	Med-Low**	1,350	40	1,290	41	1,250	43	1,205	44	1,165	46	1,110	48	1,035	52	945	56
	Low	1,215	44	1,160	46	1,105	48	1,065	50	1,025	52	980	54	925	58	860	62
072C5XE Side + Bottom or 2 Sides (72,000)	High*	2,050	26	1,960	27	1,880	28	1,800	30	1,710	31	1,630	33	1,550	34	1,460	37
	Med-High	1,955	27	1,870	29	1,800	30	1,715	31	1,655	32	1,575	34	1,485	36	1,390	38
	Med-Low**	1,365	39	1,300	41	1,260	42	1,220	44	1,175	45	1,120	48	1,045	51	955	56
	Low	1,225	44	1,170	46	1,115	48	1,075	50	1,035	52	985	54	935	57	865	62

Table 3. Maximum Airflow & Temperature Rises (° F) - Upflow / Horizontal Furnaces

BLOWER PERFORMANCE - GUH Continued

GUH80A - UPFLOW / HORIZONTAL FURNACES - 80+ AFUE																	
Model Number & Heating Input (Btuh)	Motor Speed	External Static Pressure (Inches Water Column)															
		0.1		0.2		0.3		0.4		0.5		0.6		0.7		0.8	
		CFM	Rise	CFM	Rise	CFM	Rise	CFM	Rise	CFM	Rise	CFM	Rise	CFM	Rise	CFM	Rise
090C5XE Bottom Return (90,000)	High*	1,940	34	1,860	36	1,790	37	1,710	39	1,625	41	1,540	43	1,450	46	1,355	49
	Med-High**	1,820	37	1,760	38	1,695	39	1,620	41	1,545	43	1,466	45	1,380	48	1,280	52
	Med-Low	1,290	52	1,245	54	1,200	56	1,155	58	1,110	60	1,060	63	995	67	915	73
	Low	1,145	58	1,110	60	1,070	62	1,035	64	1,000	67	950	70	905	74	835	80
090C5XE Side Return (90,000)	High*	2,020	33	1,935	34	1,860	36	1,780	37	1,690	39	1,600	42	1,510	44	1,410	47
	Med-High**	1,895	35	1,830	36	1,765	38	1,685	40	1,610	41	1,525	44	1,435	46	1,330	50
	Med-Low	1,345	50	1,295	51	1,250	53	1,200	56	1,155	58	1,100	61	1,035	64	950	70
	Low	1,190	56	1,155	58	1,115	60	1,075	62	1,040	64	980	68	940	71	870	77
090C5XE Side + Bottom or 2 Sides (90,000)	High*	2,040	33	1,955	34	1,880	35	1,795	37	1,705	39	1,620	41	1,525	44	1,425	47
	Med-High**	1,910	35	1,850	36	1,780	37	1,700	39	1,625	41	1,540	43	1,450	46	1,345	50
	Med-Low	1,355	49	1,310	51	1,260	53	1,215	55	1,165	57	1,115	60	1,050	63	960	69
	Low	1,205	55	1,165	57	1,125	59	1,085	61	1,050	63	1,000	67	950	70	875	76
108C5XE Bottom Return (108,000)	High*	2,205	36	2,150	37	2,095	38	2,030	39	1,970	41	1,900	42	1,830	44	1,740	46
	Med-High**	2,050	39	1,995	40	1,955	41	1,895	42	1,840	43	1,775	45	1,700	47	1,610	50
	Med-Low	1,700	47	1,680	48	1,645	49	1,610	50	1,565	51	1,525	52	1,460	55	1,375	58
	Low	1,390	58	1,370	58	1,355	59	1,320	61	1,300	62	1,270	63	1,225	65	1,175	68
108C5XE Side Return (108,000)	High*	2,295	35	2,235	36	2,180	37	2,110	38	2,050	39	1,975	41	1,900	42	1,810	44
	Med-High**	2,130	38	2,075	39	2,035	39	1,970	41	1,915	42	1,845	43	1,765	45	1,675	48
	Med-Low	1,770	45	1,750	46	1,710	47	1,675	48	1,630	49	1,585	50	1,520	53	1,430	56
	Low	1,445	55	1,425	56	1,410	57	1,375	58	1,350	59	1,320	61	1,275	63	1,225	65
108C5XE Side + Bottom or 2 Sides (108,000)	High*	2,315	35	2,260	35	2,200	36	2,130	38	2,070	39	1,995	40	1,925	42	1,825	44
	Med-High**	2,155	37	2,095	38	2,055	39	1,990	40	1,930	41	1,865	43	1,785	45	1,690	47
	Med-Low	1,785	45	1,765	45	1,725	46	1,690	47	1,645	49	1,600	50	1,535	52	1,445	55
	Low	1,460	55	1,440	56	1,425	56	1,385	58	1,365	59	1,335	60	1,285	62	1,235	65
126D5XE Bottom only or 2 openings (126,000)	High*	2,255	41	2,200	42	2,125	44	2,065	45	2,010	46	1,935	48	1,855	50	1,755	53
	Med-High**	2,075	45	2,025	46	1,970	47	1,940	48	1,875	50	1,810	52	1,750	53	1,680	56
	Med-Low	1,720	54	1,695	55	1,655	56	1,630	57	1,580	59	1,520	61	1,455	64	1,390	67
	Low	1,360	69	1,375	68	1,365	68	1,315	71	1,310	71	1,300	72	1,260	74	1,230	76
126D5XE Side Return (126,000)	High*	2,230	42	2,180	43	2,105	44	2,045	46	1,990	47	1,915	49	1,835	51	1,740	54
	Med-High**	2,055	45	2,005	47	1,950	48	1,920	49	1,855	50	1,790	52	1,735	54	1,665	56
	Med-Low	1,705	55	1,680	56	1,640	57	1,615	58	1,565	60	1,505	62	1,440	65	1,375	68
	Low	1,345	69	1,360	69	1,350	69	1,300	72	1,230	76	1,290	72	1,250	75	1,220	77

NOTES:

* Factory Set Cooling Speed

** Factory Set Heating Speed

- Two openings are recommended for airflows above 1,600 CFM if filter(s) is(are) adjacent to furnace
- Temperature rises in the table are approximate. Actual temperature rises may vary.
- Temperature rises shaded in gray are for reference only. These conditions are not recommended.

Table 3. Continued

BLOWER PERFORMANCE - GDD Continued

GDD80A - DOWNFLOW FURNACES - 80+ AFUE																	
Model Number & Heating Input (Btuh)	Motor Speed	External Static Pressure (Inches Water Column)															
		0.1		0.2		0.3		0.4		0.5		0.6		0.7		0.8	
		CFM	Rise	CFM	Rise	CFM	Rise	CFM	Rise	CFM	Rise	CFM	Rise	CFM	Rise	CFM	Rise
054A3XE (54,000)	High*	1,375	29	1,340	30	1,300	31	1,270	31	1,225	33	1,175	34	1,115	36	1,035	39
	Med-High	1,155	35	1,130	35	1,110	36	1,085	37	1,055	38	1,015	39	975	41	910	44
	Med-Low**	790	51	775	52	765	52	750	53	730	55	700	57	665	60	610	66
	Low	650	62	640	63	630	63	610	66	590	68	565	71	530	75	480	83
072B4XE (72,000)	High*	1,675	32	1,655	32	1,640	33	1,620	33	1,590	34	1,560	35	1,520	35	1,475	36
	Med-High	1,330	40	1,315	41	1,300	41	1,280	42	1,255	42	1,230	44	1,200	44	1,150	46
	Med-Low**	1,180	45	1,165	46	1,150	46	1,135	47	1,115	48	1,090	50	1,060	50	1,010	53
	Low	940	57	925	58	900	59	880	61	850	63	825	65	795	67	760	70
090B4XE (90,000)	High*	1,610	41	1,590	42	1,575	42	1,560	43	1,540	43	1,495	46	1,460	46	1,415	47
	Med-High	1,295	51	1,275	52	1,260	53	1,250	53	1,220	55	1,195	57	1,170	57	1,120	60
	Med-Low**	1,155	58	1,235	54	1,115	60	1,095	61	1,065	63	1,040	66	1,015	66	980	68
	Low	910	73	885	75	860	78	835	80	810	82	785	85	765	87	735	91
108C5XE (108,000)	High*	2,395	33	2,335	34	2,285	35	2,230	36	2,200	36	2,140	37	2,080	38	2,000	40
	Med-High	2,190	37	2,135	37	2,115	38	2,080	38	2,030	39	1,975	41	1,915	42	1,810	44
	Med-Low**	1,785	45	1,770	45	1,740	46	1,725	46	1,685	47	1,645	49	1,615	50	1,565	51
	Low	1,145	70	1,110	72	1,070	75	1,035	77	1,000	80	950	84	905	88	835	96
126D5XE (126,000)	High*	2,445	38	2,395	39	2,385	39	2,330	40	2,275	41	2,225	42	2,130	44	2,015	46
	Med-High	2,195	43	2,170	43	2,140	44	2,120	44	2,090	45	2,030	46	1,975	47	1,855	50
	Med-Low**	1,795	52	1,780	52	1,770	53	1,760	53	1,725	54	1,690	55	1,655	56	1,610	58
	Low	1,480	63	1,475	63	1,450	64	1,440	65	1,440	65	1,415	66	1,405	66	1,375	68

NOTES:

* Factory Set Cooling Speed

** Factory Set Heating Speed

1. Temperature rises in the table are approximate. Actual temperature rises may vary.

2. Temperature rises shaded gray are for reference only. These conditions are not recommended.

Table 4. Maximum Airflow & Temperature Rises (° F) - Downflow Furnaces

MODEL IDENTIFICATION CODE

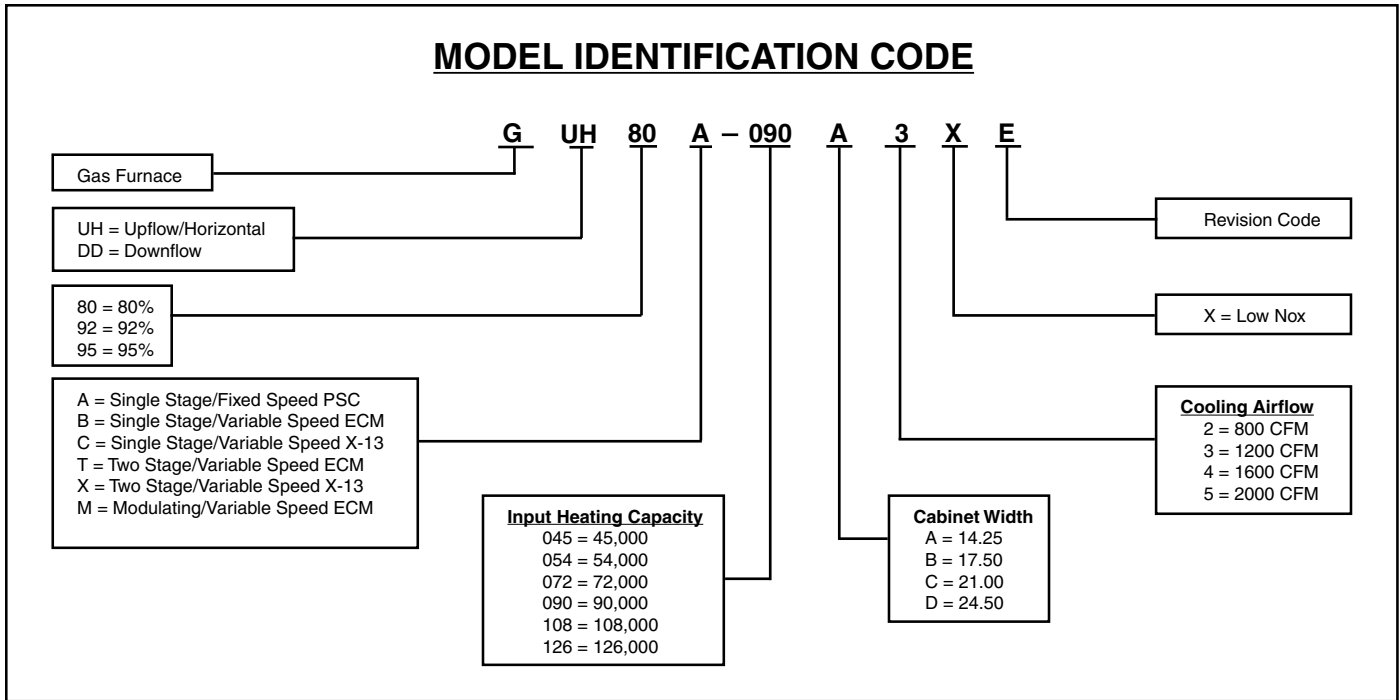

SPECIFICATIONS

GUH80 MODEL NUMBERS	-045A3XE	-054A3XE	-072B4XE	-090B4XE	-072C5XE	-090C5XE	-108C5XE	-126D5XE
Input - Btuh (a)	45,000	54,000	72,000	90,000	72,000	90,000	108,000	126,000
Heating Capacity - Btuh	36,000	43,200	57,600	72,000	57,600	72,000	86,400	100,800
AFUE	80.0	80.0	80.0	80.0	80.0	80.0	80.0	80.0
Blower D x W	10 x 6	10 x 6	11 x 8	11 x 8	10 x 10	10 x 10	11 x 10	11 x 10
Motor H.P. - Speed - Type	1/3 - 4 - PSC	1/3 - 4 - PSC	1/2 - 4 - PSC	1/2 - 4 - PSC	1/2 - 4 - PSC	1/2 - 4 - PSC	1.0 - 4 - PSC	1.0 - 4 - PSC
Motor FLA	4.80	4.80	8.20	8.20	7.50	7.50	13.75	13.75
Rated Ext. SP - In. W.C.	0.5	0.5	0.5	0.5	0.5	0.5	0.5	0.5
Temperature Rise Range - °F	30-60	30-60	35-65	35-65	35-65	35-65	40-70	40-70
Shipping Weights	100lbs	100lbs	110lbs	115lbs	115lbs	120lbs	125lbs	145lbs

GDD80 MODEL NUMBERS	-054A3XE	-072B4XE	-090B4XE	-108C5XE	-126D5XE
Input - Btuh (a)	54,000	72,000	90,000	108,000	126,000
Heating Capacity - Btuh	43,200	57,600	72,000	86,400	100,800
AFUE	80.0	80.0	80.0	80.0	80.0
Blower D x W	10 x 6	11 x 8	11 x 8	11 x 10	11 x 10
Motor H.P. - Speed - Type	1/3 - 4 - PSC	1/2 - 4 - PSC	1/2 - 4 - PSC	1.0 - 4 - PSC	1.0 - 4 - PSC
Motor FLA	4.80	8.20	8.20	13.75	13.75
Rated Ext. SP - In. W.C.	0.5	0.5	0.5	0.5	0.5
Temperature Rise Range - °F	30-60	35-65	35-65	40-70	40-70
Shipping Weights	100lbs	110lbs	115lbs	125lbs	145lbs

ACCESSORIES

Description	SKU
"A" Cabinet fixed speed, high efficiency, FSHE	904872
"B" Cabinet fixed speed, high efficiency, FSHE	904873
"C" Cabinet fixed speed, high efficiency, FSHE	904874
"D" Cabinet fixed speed, high efficiency, FSHE	904875
"A" Cabinet variable speed, high efficiency, VSHE	904876
"B" Cabinet variable speed, high efficiency, VSHE	904877
"C" Cabinet variable speed, high efficiency, VSHE	904878
"D" Cabinet variable speed, high efficiency, VSHE	904879
"A" Cabinet downflow sub base kit	902974
"B", "C", "D" Cabinet downflow sub base kit	904911
U.S. LP Conversion kit (0 to 10,000 ft.)	905028
Canada LP Conversion kit (0 to 4,500 ft.)	905029
Side return filter kit	541036



HEAT CONTROLLER

1900 Wellworth Ave. Jackson, MI 49203

Printed in U.S.A (09/2016)